

# Carbon Fixation of a Microalgae *scenedesmus sp.* Pilot Culture under Different Nutritional Inputs

José F. Reyes<sup>1\*</sup>, Cristian Inostroza<sup>2</sup>

<sup>1</sup>Faculty of Agricultural Engineering, Universidad de Concepción,  
Chillán, Chile

<sup>2</sup>Chemical Engineering Department, University of Almeria, Ctra. Sacramento  
Almería, Spain

\*Corresponding Author's Email Address: jreyes@udec.cl

---

**ABSTRACT**— A culture of the microalgae *Scenedesmus sp.* in a pilot closed raceway photo bioreactor (CRPB), with flue gas injection from a diesel engine was implemented. Two different nutritional medium, Z-8 and EPA were used to feed the culture growth that was monitored in terms of total and partial biomass productivity, carbon fixation and oil production during nine days. The system was sequentially sampled measuring the gas flow and concentration of the injected CO<sub>2</sub>, the amount of biomass harvested and the concentration of CO<sub>2</sub> in the degassing flow. In addition, the pH was measured in the culture to assess the amount of CO<sub>2</sub> instantaneously dissolved. The results at the steady state, showed a carbon fixation efficiency ranging between 21.6 % and 44.9 %, and that the Z-8 medium was clearly better than the EPA in terms of CO<sub>2</sub> capture and therefore biomass and oil production. A continuous increasing of oil content in microalgae biomass up to 6.6 % dry basis, with maximum oil production rate of 2.27 g m<sup>-3</sup>d<sup>-1</sup> was observed, with a maximum rate of biomass production of 44.97 g m<sup>-3</sup>d<sup>-1</sup> and a maximum carbon capture rate of 2.27 g m<sup>-3</sup>d<sup>-1</sup> was achieved with the culture medium Z-8.

**Keywords**— microalgae, abatement, raceway, flue gas, algal oil

---

## 1. INTRODUCTION

It is estimated that there are over 50,000 varieties of microalgae but a limited number of around 30,000 have been studied and analyzed [1] (Mata et al., 2009). Use of microalgae biomass have been proposed for commercial applications, mainly as a source of animal and human food and also as a source of bioenergy [2] Spolaore et al. (2006). Bioenergy from microalgae products includes: (i) the biogas produced by anaerobic digestion or co-digestion of microalgae biomass, (ii) electricity by direct combustion of biomass or indirectly through combustion biogas derived from microalgae, (iii) the biodiesel after oil extraction and re-esterification with mono short chain alcohols, (iv) ethanol by fermentation; and (v) liquid fuels through thermo chemical, such as pyrolysis, gasification and liquefaction conversions. Biofixation of CO<sub>2</sub> by microalgae aquaculture is nowadays subject of great attention as a technology that can contribute to reduce the effect of greenhouse gases in global warming [3] Benemann, J.R., 2003, [4] Woerz et al., 2009. Recent economical assessments to reduce greenhouse gases has shown that the most feasible scenario to produce biofuels from microalgae requires the use CO<sub>2</sub> rich flue gas from industrial power plants as source of carbon [5] (Monari et al., 2016). It is assumed that about the 85 % of the CO<sub>2</sub> in the flue gases can be removed using photobioreactor microalgae cultivation [6] (Maity et al., 2014). Several different microalgae strains have been considered candidates to implement these culture systems, especially those showing high rates of biomass productivity as those pertaining to type species of *Chlorella* and *Scenedesmus*, [7] Matsunaga et. al, [8] Quevedo et al., [9] Lara. In improving biomass productivity and therefore the capacity of carbon biofixation, besides CO<sub>2</sub> availability, an appropriate nutritional input has to be supplied, which can be chosen from a collection of different formulations that has been proposed [10] Grobbelaar 2004. The other factor relevant to enhance biomass productivity and carbon fixation is the rate of dissolution of CO<sub>2</sub> into the liquid culture [11] Camacho et al. 1999, greatly influenced by the type and design of the photobioreactor deployment [12] Carvalho et al. [13], Contreras et al. [14] Molina et al. Waste gases of combustion processes typically contain levels of CO<sub>2</sub> larger than 15% (vv<sup>-1</sup>) that provide sufficient supply for large scale production of microalgae [15] (Kumar et al., 2010). Microalgae can also use effectively as other gases as nutrients, such as NO<sub>x</sub> and SO<sub>x</sub> [16] (Olaizola et al., 2006), however they can be toxic, depending on the species of microalgae and the concentrations of these gases in the medium. The usual sources of CO<sub>2</sub> to microalgae include: (i) atmospheric CO<sub>2</sub>; (ii) CO<sub>2</sub> from industrial exhaust gas and (iii) CO<sub>2</sub> chemically fixed in the form of soluble carbonates (e.g. NaHCO<sub>3</sub> and Na<sub>2</sub>CO<sub>3</sub>). The tolerance of several microalgae species to CO<sub>2</sub> concentration is variable; however, the CO<sub>2</sub> concentration in the gas phase does not necessarily reflect the concentration of CO<sub>2</sub> at which the microalgae is exposed during dynamic liquid suspension, depending on the pH and the

concentration gradient of CO<sub>2</sub> created by the resistance to transfer of mass. Yoo et al. (2010) [17] studied the behavior of three strains *Botryococcus braunii*, *Chlorella vulgaris* y *Scenedesmus* sp., which were cultured with 5.5 % and 10% of CO<sub>2</sub> for mitigating CO<sub>2</sub> emissions and also for the production of biodiesel. They calculated that about 24 % of CO<sub>2</sub> can be eliminated by incorporating into the microalgae biomass production. The lipid content for *Scenedesmus* sp. was lower than for *B. braunii*, but total lipid productivity was 20.65 mg L<sup>-1</sup>d<sup>-1</sup>. The total lipid content of both *Scenedesmus* sp. and *C. vulgaris* were below 11.92 % dry weight while for *B. braunii* during the day 7 and day 14 the total lipid content was 25.79 % and 21.10 % dry weight, respectively. The conclusion was that biomass productivity of *Scenedesmus* sp. was 2.8 times that of *B. braunii* and *C. vulgaris*. With flue gas containing 5.5 % CO<sub>2</sub>, *B. braunii* and *Scenedesmus* sp. showed a higher growth rate similar to the test with 10 % CO<sub>2</sub>. Especially, *B. braunii* reached higher lipid content and oleic acid composition. Hernandez-Reyes et al. (2009) [18] when analyzing two different strain of the *Scenedesmus*, applying 0.5 air volume/medium volume-min (vvm<sup>-1</sup>) of aeration, and a light intensity of 200 mmol m<sup>-2</sup>s<sup>-1</sup> with photoperiod light/dark of 12h/12h in PCG culture medium, determined at 14 days that the strain of *Scenedesmus incrassatulus* presented a value of 8.2% total lipids, higher than 7.02 % showed by *Scenedesmus* sp. Ho et al. (2010) [19] studied CO<sub>2</sub> mitigation and lipid production of a strain of *Scenedesmus obliquus* in two stages, the first rich in nutrients to promote growth of cells and a second, weak in N and P. According to this research, the main fatty acids produced were of 17.16 % of stearic acid (C18:0), 15.55 % of oleic acid (C18:1), 15.06 % of palmitic acid (C16:0), 13.39 % of linoleic acid (C18:2), 3.97 % of linolenic acid (C18:3) and 2.30% of palmitoleic acid (C16:1). In the second stage, with nutrition deficient in N and P, near 25% of C18:0 and 30% of C18:1 was obtained. The highest daily production in the first stage was 292.50 mg L<sup>-1</sup>d<sup>-1</sup> of biomass, 78.73 mg L<sup>-1</sup>d<sup>-1</sup> of lipids and a consumption of CO<sub>2</sub> of 549 mg L<sup>-1</sup>d<sup>-1</sup>. When Moraes et al. (2016) [20] studied the influence of different types of diffusers and flow rates of pure CO<sub>2</sub> in biomass productivity of a photo bioreactor with a culture of *spirulina* sp. They obtained a maximum biomass production of 125.9 mg L<sup>-1</sup>d<sup>-1</sup> with the best combination of these two factors.

The goal of this study was to evaluate the effect of two different culture media in the biomass productivity of *scenedesmus* sp., in terms of total biomass gained, lipids produced and carbon sequestration, in a close raceway photobioreactor, with flue gas injection as source of CO<sub>2</sub>.

## 2. MATERIALS AND METHODS

### 2.1 Configuration of equipment and tests

The study was conducted at the University of Concepción, Faculty of Agricultural Engineering, located in the city of Chillan, Chile. The work included two pilot closed Raceway photobioreactors with net capacity of 1400 L each, configured for injection of exhaust internal combustion gas of a diesel engine to both reactors simultaneously on daily basis from 10.00 AM to 18.00 PM for nine days. Two different culture media were used in each of the photobioreactors. One them poor in nutrients especially N and P called the EPA formula and the other rich in those elements which is the Z-8 culture media. Previous to pilot photobioreactor testing of the culture, a 5 L sample of a Chilean *scenedesmus* sp. endemic strain supplied by the Biology Department of the University of Concepción, was raised and then cultivated in a battery of 10 small photobioreactors 30 L each, using a 1 L of a mixture of 50% of EPA and 50% of Z-8 for nutrition in each reactor. The resulting 300 L were homogenized and divided into a pair of 150 L charges to each of the pilot photobioreactors, with added water to reach the total capacity of 1400 L. Then, 24 L of EPA solution was added to the first photobioreactor and 24 L of Z-8 to the second one. In these reactors, the variables evaluated were biomass productivity, productivity of lipids and carbon capture rate during the period from 20 to 29 December 2014. To generate the flue gas, a diesel engine (KM170F, Kipor, China) running with biodiesel B100 at 3,200 rpm, was connected to the culture system. The engine worked daily for a period of 8 hours to fully injecting the exhaust gas flow of 25 L min<sup>-1</sup> into the gas cleaning system and then divided into 12.5 L min<sup>-1</sup> to each of the photobioreactors in parallel. Previous to the injection into the photobioreactors, the engine flue gas passed through a cooling and cleaning unit comprised of three sections as follows: (i) a water pressurized bubbling chamber of 30 L of used to retain the large particulate material from the soot of the combustion gas, with a pressure gauge for control of chamber pressurization (ii) a set of eight carbon steel tubes of 5 mm diameter and 1.5 m long for gas cooling and (iii) a gas surface filter of radial flow to capture most of the fine particulate matter not retained in the bubbler. The photobioreactors used were built in semitransparent fiber glass, with a useful capacity of 1.4 m<sup>3</sup> with a 3 mm thick polycarbonate sheet of high transmittance as top cover. The flue gas was fed to each photobioreactor by means of Polyvinyl Chloride (PVC) tubing consisting of a main line of 25 mm in diameter connected to a pair of parallel tubes each one with 20 micro gas injectors located in the bottom of the reactor. Stirring of the culture in the photobioreactor was accomplished by means of the vanes of an impeller rotating at 10 rpm and driven by a 100 W electric motor (Fig. 1). A data acquisition module with two sensors, pH and temperature was installed in each photobioreactor for monitoring those variables along the period of the experiment [21] Hernandez.

### 2.2 Biomass productivity

To monitor the evolution of biomass increase, transmittance of the culture was measured every other day until day 8 and also day 9 in triplicate, using a spectrophotometer (model Spectronic 20, Fischer Scientific, USA). The instrument

was adjusted to a wavelength of 640 nm as a reference value of high absorbance for this type of strain. Additionally the daily turbidity of the medium was measured every other day until day 8 and also day 9, in triplicate by a turbid meter (model 2100P, Hach Lang, USA), with sensitivity of 0-1000 NTU using the principle of light not scattered by particles suspended (Lara, 2011). A drop of the microalgae suspension was deposited on a glass plate and examined with a microscope (Axiostar Plus, Zeiss, Germany) to verify the physical integrity of the strain, from where a digitalized image

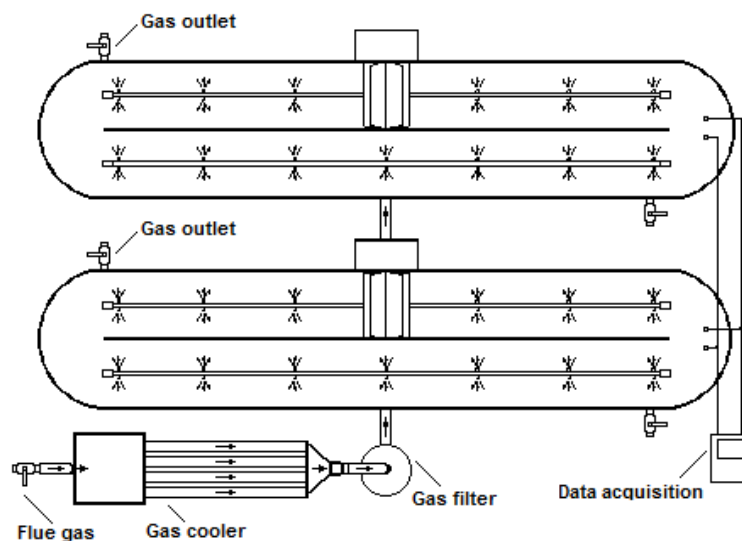

**Figure 1:** Pilot culture system schematic

was saved. Additionally, a volume of 60 L was harvested and centrifuged every other day until day 8 and also day 9, by means of a centrifuge (model 130, Bertuzzi SAT, Italy). The obtained slurry of low extracellular moisture was dried 48 hours at 103-105 °C, in a natural convection stove (model Hotbox, Gallenkamp, UK). Once the sample achieved the ambient temperature, the percentage of dry mass was quantified gravimetrically employing an analytical scale, brand Electronic Balance, model FA2104N with sensitivity of 0.1 mg. The pH was measured daily in the photobioreactors every 2 hours from the beginning of flue gas injection at 10:00 am until 18:00 pm, using a portable pH meter (Model 50, Griffin, UK). The quantification of the mass percentage of CO<sub>2</sub> in the inlet and outlet gas stream was performed by triplicate, by the Orsat method (model FYRITE, Bacharach, USA), with a sensitivity of 0-20% CO<sub>2</sub>. By mass balance of the amount of carbon in the incoming gas and the amount of captured carbon as microalgae biomass, the percentage of fixed or abated carbon was determined.

### 2.3 Solubility of CO<sub>2</sub>

In order to assess the concentration of dissolved CO<sub>2</sub> in the culture, daily samples of 10 mL in triplicate were taken and treated by differential titration using HCl 0.01 N. In the first step 10 ml of a solution of Ba(OH)<sub>2</sub> was titrated with HCl:



In the second titration a culture sample of 10 mL was added to the reaction, where the CO<sub>2</sub> consumes part of the Ba(OH)<sub>2</sub> to form BaCO<sub>3</sub>:

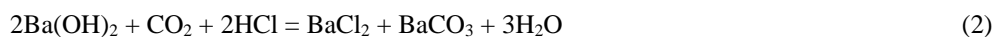

The CO<sub>2</sub> concentration then was determined proportionally to the differential consumption of HCl between both titrations.

### 2.4 Profile of lipids

Testing for determination of lipid content was done using 10 g of dry matter samples obtained from the productivity tests. Oil extraction was performed by means of Soxhlet distillers, with petroleum ether as solvent for a period of 5 hours. Once the extraction completed, the solvent was removed in an evaporator (model VV2000, Heidolph, Germany) with temperature regulated bath and vacuum pump (model S55PY-3331, Emerson, USA). Then percentage of oil of each sample was determined by gravimetry using an analytical balance (model FA2104N, Jinghai, China) with sensitivity of

0.1 mg. To assess the lipid profile a chromatographic analysis was carried out on a gas chromatograph (model Varian 3900, Coleparmer, USA). The oil extract sample from microalgae was esterified and subsequently injected into the chromatograph to measure retention times of the various fatty acids contained in the extract.

### 3. RESULTS AND DISCUSSION

#### 3.1 Biomass productivity

The transmittance results indicate that in the initial period, in the photobioreactor fed with the nutritional medium EPA, it remains approximately constant, indicating slow growing of the biomass, which can be interpreted as a phenomenon of latency or upgrading to new culture medium, poor in nutrients. In the case of the culture with Z-8, the initial decrease of transmittance indicates immediate multiplication activity of the strain, probably due to the greater availability of nutrients (Fig. 2a). Turbidity measurements, which are inversely proportional to the transmittance parameter, corroborate the above described behavior in the initial stage of culture (Fig. 2b), where a sharp increase in the concentration of culture biomass fed Z-8 is found and invariance of biomass growing in the photobioreactor fed with EPA. Observations with the microscopy confirm this behavior, showing that with EPA strain cells remained primarily in groups of 2 (Fig. 3a), unlike what happens with the Z-8 medium wherein groups of 4 cells are observed (Fig. 3b), consistent with the level of energy and nutrients available.

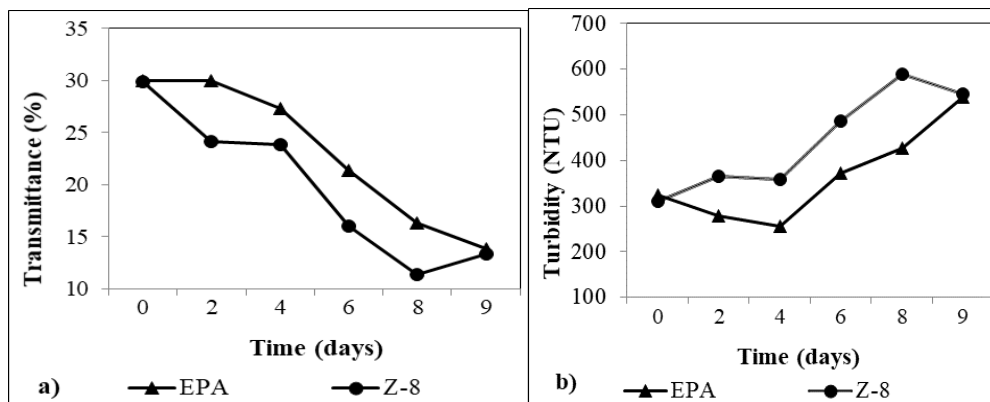

Figure 2: Comparative evolution of transmittance and turbidity

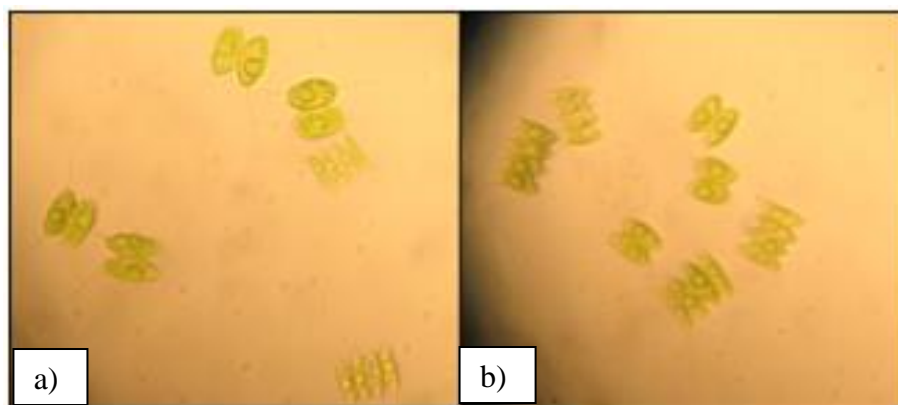

Figure 3: Microscopy of cell growing, a) EPA, b) Z-8

From the third day ahead, a period in which both culture media generate a large decay in transmittance and consequently an increase in turbidity is observed, indicating a significant improvement in the biomass growth rate. In the final phase of the period in study, starting day eight, it can be seen that in culture medium EPA, the strain is able to further raise its productivity, possibly due to the fact that its metabolism was adapted to a slower multiplication rate, conditioned by the nutritional profile of the EPA medium. In contrast, the biomass growing rate of the culture in medium Z-8 apparently remain almost unchanged, showing a possibly depletion of nutrient availability. In summary, the results of biomass productivity indicate that it is possible to identify three conditions during the production cycle of the two experiences, using EPA and Z-8 as culture medium (Fig. 4). In the first two days a strain conditioning process is

observed probably derived from different concentrations of available nutrients. The Z-8 medium showed no growing problem of the culture at this stage since high concentrations of nutrients were supposed in the photobioreactor. The second period shows that from day three up to day eight, strains are already fully adapted to the media and may tend to an almost constant growing rate, corresponding to the most productive stage of the culture. In the third period, from day nine on, the biomass productivity remains near constant for Z-8 medium, while for the EPA medium the production rate of biomass is still increasing.

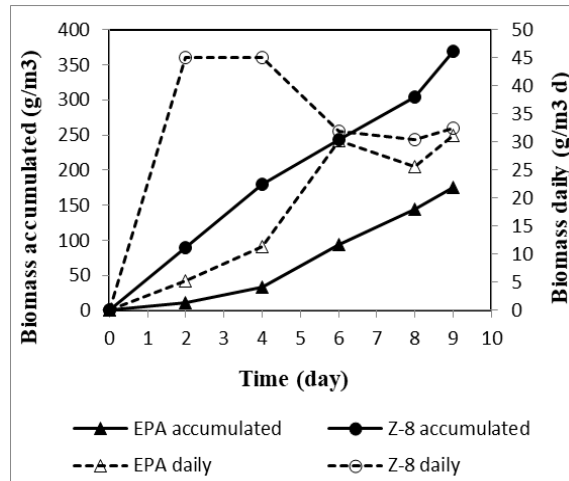

Figure 4: Comparative biomass productivity

The EPA medium, due to its lower nutrient concentration generated a lower cumulative productivity of  $176.1 \text{ gm}^{-3}$  with a daily average biomass growing rate of  $19.6 \text{ g m}^{-3}\text{d}^{-1}$ , unlike the Z-8 medium which induced a cumulative productivity of  $369.6 \text{ g m}^{-3}$  and a daily average biomass growing rate of  $41.1 \text{ g m}^{-3}\text{d}^{-1}$ , which shows its superiority as a culture medium in this comparative test. It is important to consider that the testing started with an initial biomass concentration of  $363 \text{ gm}^{-3}$  in both photobioreactors, corresponding to a value of turbidity of 310 NTU, because the turbidity is a factor that can limit the light incidence and therefore the biomass production rate. Yoo et al. (2010) obtained a maximum productivity of  $217.5 \text{ g m}^{-3}\text{d}^{-1}$  although they used a  $\text{CO}_2$  concentration of 10% in the flue gas. Ho et al. (2010) obtained  $292.5 \text{ g m}^{-3}\text{d}^{-1}$  using the strain *Scenedesmus obliquus* CNW-N.

### 3.2 Carbon fixation and lipids productivity

The amount of carbon fixed as function of time, shows a similar trend to biomass production, with some minor differences between the two-culture media tested. For the EPA culture medium, a constant proportionality between these two variables is observed over the entire period studied (Fig. 5).

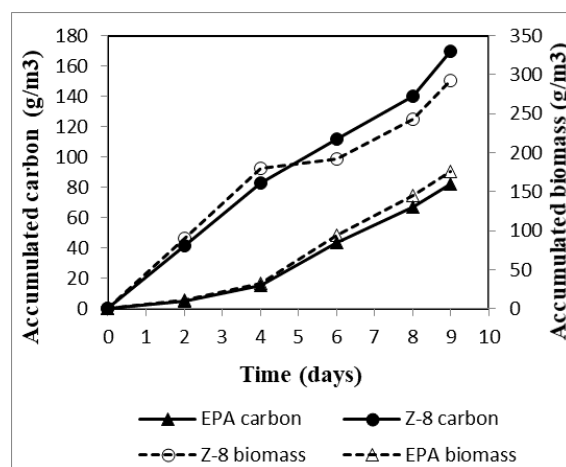

Figure 5: Biomass productivity and carbon fixation

It is further noted that the daily rate of carbon fixation follows the same trend (Fig. 6a). However, when using the Z-8 medium, there is a transition between the fourth and sixth day and then returning to the proportionality between the lipid content in biomass and the daily rate of carbon uptake. The explanation of this phenomenon might be the beginning of the period of depletion of nitrogen, the main promoter of biomass growth. This phenomenon is consistent with the culture behavior observed when comparing the lipid content with the daily rate of carbon sequestration (Fig. 6b), which shows that although the lipid content in biomass increases from day sixth, carbon daily captured goes down, possibly because the ratio between protein and carbohydrate ratio decreases by the reduced availability of nitrogen, since the carbon content of carbohydrates is lower than proteins. It is also clear that both, the average lipid gain and the lipid content in the biomass are higher for the Z-8 culture (Fig. 6).

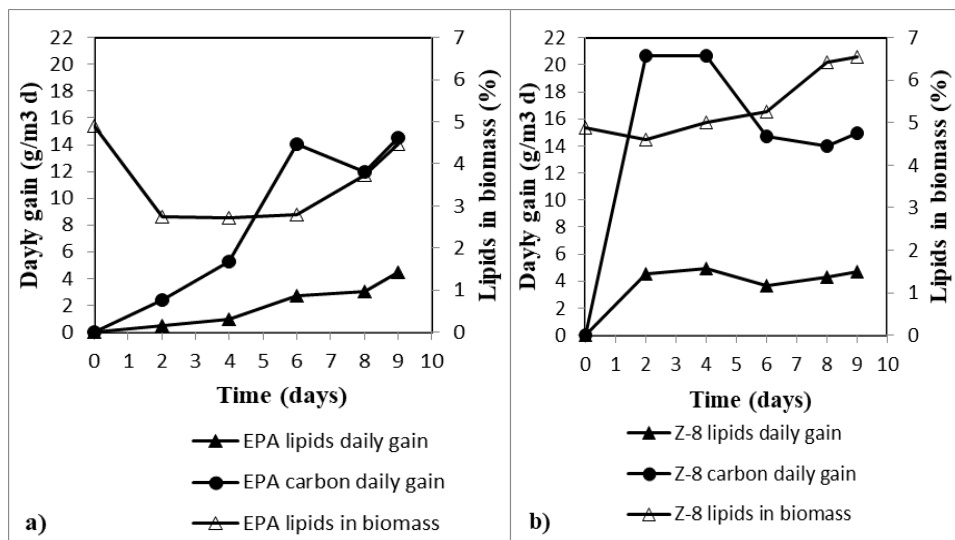

Figure 6: Carbon fixation and lipid productivity

On the other hand, Fig. 6 shows that there is a coherency between the daily rate of lipid production and the rate of carbon fixation for both culture media, a situation that is consistent with the chemical composition of lipids, which have considerably greater carbon content than carbohydrates and proteins. Yoo et al. (2010) reported that up to 14 days of process, with 5.5 and 10 % of CO<sub>2</sub> injection, the lipids in biomass obtained were 11.92%, and the accumulated lipid productivity with the Z-8 medium through the ninth day was similar.

The figures of daily productivity of lipids compared to biomass, permits to visualize that for both formulas of nutrition, there is a direct proportionality between the productivity of biomass and lipids, in the initial conditioning period and until the day six ( Fig. 7). In this period also the lipid productivity obtained with the nutrient medium Z-8 is significantly higher than with EPA, which initially generates very low productivity but the biomass and lipids increases linearly until the sixth day, approaching the value obtained with the Z-8 medium. From day six on, the trend of proportionality between biomass and lipids appears uncoupled for both culture media, noting that the rate of increase of lipid productivity is higher than that of biomass. One possible explanation for this phenomenon could be that in a scenario of nutrient depletion, a reconversion between carbohydrates and proteins to lipids may occur [22] Guschina and Harwood.

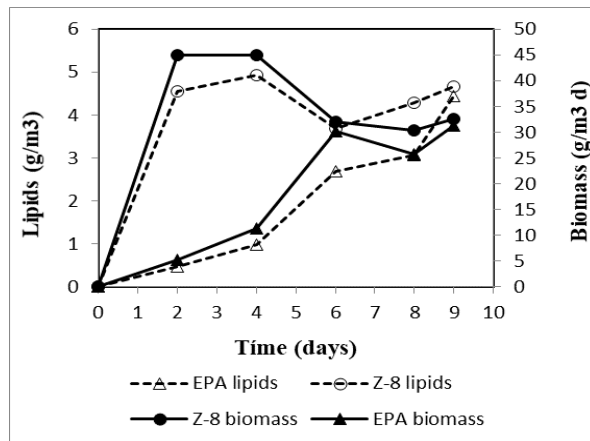

Figure 7: Comparison of lipid daily productivity

The analysis of the concentration of dissolved carbon in the culture during the process, indicates a slight decrease in concentration over time, with both nutritional sources, which is consistent with the rate of accumulation of biomass (Fig. 8). However, the percentage of fixed carbon to total carbon available regarding the cultivation has different behaviors for the two nutritional formulas tested. With EPA medium, the percentage of captured carbon is initially very low but grows approximately linear. (Fig. 8a), showing that the efficiency of carbon fixation has a steady increase over time. On the other hand, the Z-8 medium presents no considerable variation in terms of percent carbon fixation over time (Fig. 8b.), maintaining a high capture efficiency throughout the process. In both cases, the maximum efficiency of carbon capture close to 16% and the lowest level of dissolved carbon, approximately  $12 \text{ g m}^{-3}$  is reached at the ninth day.

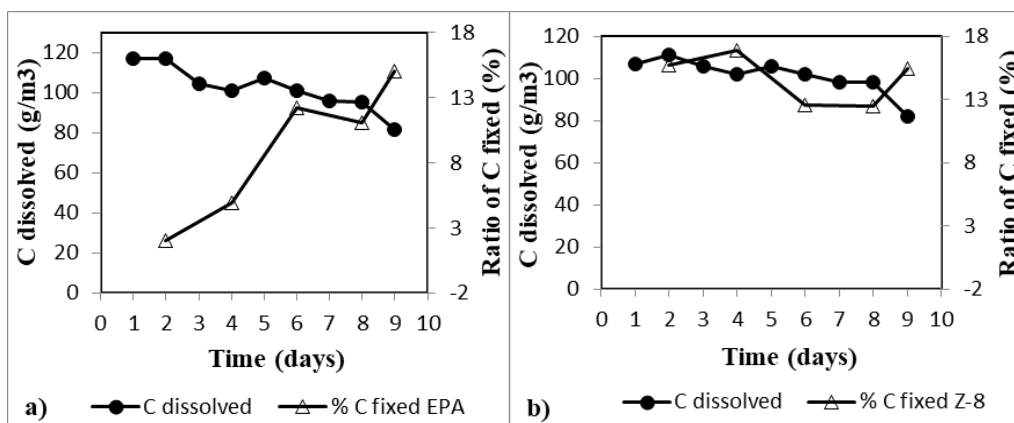

Figure 8: Dissolved and fixed carbon

The average observed values of dissolved carbon dioxide with EPA and Z-8 culture medium were  $379$  and  $385 \text{ g m}^{-3}\text{d}^{-1}$  respectively, for a period of eight hours of  $\text{CO}_2$  daily injection. Ho *et al.* (2010) obtained an average of  $549 \text{ g m}^{-3}\text{d}^{-1}$  and decreasing over the time, a greater value that was reached with a concentration of 10 %  $\text{CO}_2$  during twelve hours of daily gas injection. In addition, the total carbon balance indicates that during the period studied, the total carbon fixed was 21.6 % when the medium EPA was used and 44.9 % when the culture utilized the medium Z-8 as nutritional input (Table 1). These results are comparable with those obtained by Yoo *et al.* (2010) who estimated that about 24 % of  $\text{CO}_2$  can be mitigated. They worked with rates higher carbon dioxide (5.5 and 10 %) but used a system with combustion fuel gas at a higher temperature where the gas tried to pass through the open liquid column of microalgae, at a higher speed and exhausting to the atmosphere. The reactor used in the present experimental work instead, had an upper lid avoiding direct exhaust gas to atmosphere and where besides, the mechanical agitation system improved mass transfer between the dioxide gas and the liquid culture.

Table 1: Mass balance of carbon

Culture media	Daily C input ( $\text{gm}^{-3}\text{d}^{-1}$ )	Total C input ( $\text{gm}^{-3}$ )	Total C fixed ( $\text{gm}^{-3}$ )	% C fixed
EPA	42.08	378.72	81.86	21.6
Z-8	42.08	378.72	170.04	44.9

Laboratory analysis of lipid profile allowed detecting the most important fatty acids present in the biomass for the sample with the best productivity of lipids, which was the microalgae culture treated with the Z-8 medium. Among the most important fatty acids identified, those of 16 and 18 carbons were the majority, highlighting the productivity in polyunsaturated fatty acids of *scenedesmus sp.* with an appropriate nutritional source (Table 2). These results are consistent with the investigation of Hernandez-Reyes et al. [18] who not only detected the major presence of the same fatty acids, but also found significant amounts of stearic (18: 0) and palmitoleic (16: 1).

**Table 2:** Profile of lipids in microalgae biomass

Fatty acid	Percentage (%)
Palmitic (C16:0)	12.16
Oleic (C18:1)	3.70
Linoleic (C18:2)	10.50
Linolenic (C18:3)	23.63

#### 4. CONCLUSION

Experimental work was performed on a pilot scale, using raceway photobioreactors with injection of flue gases, to assess the influence of two different nutritional culture media, EPA and Z-8, in the fix ability of carbon of the microalgae *Scenedesmus sp.* The system showed higher productivity of biomass with a high carbon content and a moderate lipid production when using the culture medium Z-8, with respect to the EPA medium. The efficiency of carbon capture was also higher with the nutritional medium Z-8 and similar or greater than the values obtained using flue gases of higher CO<sub>2</sub> content and longer periods of photo bioreactor operation, as reported in the literature, for the species *Scenedesmus sp.* The lipid analysis revealed the preponderant presence of polyunsaturated fatty acids, which are the most recommended for application to human and animal nutrition, as well as for the manufacture of biofuels. In consequence, when implementing a photo bioreactor microalgae technology for carbon abatement, using a culture medium similar to the formula Z-8 is recommended, due its high concentration of nutrients, especially nitrogen that allows high biomass productivity and efficiency in carbon sequestration.

#### 5. ACKNOWLEDGEMENT

The authors acknowledge the Chilean CORFO Public Research Corporation, for their support to the research project INNOVA-BIO BIO PC-08 S1-271: Development of high conversion reactors for cultivation of oleic microalgae and biodiesel production.

#### 6. REFERENCES

- [1] Mata, T.M., Martins, A.A., Caetano, N.S., “Microalgae for biodiesel production and other applications: A review”, *Renewable and Sustainable Energy Reviews* 14: 217-232, 2009.
- [2] P, Joannis-Cassan, C., Duran, E., Isambert, A., “Commercial applications of microalgae”, *J Biosci Bioeng.* 101: 87–96, 2006.
- [3] Benemann, J.R., “Technology Roadmap - Biofixation of CO<sub>2</sub> and Greenhouse Gas Abatement with Microalgae”, Final Report to the U.S. Dept. of Energy, Morgantown – Pittsburgh, January 14, 2003. Available at <http://www.ieagreen.org.uk/>, 2003.
- [4] Woerz, I.C., Fulton, L., Lundquist, T.J., “Nutrient removal & greenhouse abatement with CO<sub>2</sub>-supplemented algal high rate ponds”, Paper written for the WEFTEC annual conference, Water Environment Federation, October 12-14, 2009, Orlando, Florida, pp.13, 2009.
- [5] Monari, Ch., Righi, S., Olsen, S.I., “Greenhouse gas emissions and energy balance of biodiesel production from microalgae cultivated in photobioreactors in Denmark: a lifecycle modeling”, *Journal of Cleaner Production* 112: 4084-4092, 2016.
- [6] Maity, J.P., Bundschuh, J., Chen, C.Y., Bhattacharya, P., “Microalgae for third generation biofuel production, mitigation of greenhouse gas emissions and wastewater treatment: Present and future perspectives - A mini review”, *Energy* 78:104-113, 2014.
- [7] Matsunaga, T., Matsumoto, M., Maeda, Y., Sugiyama, H., Sato, R., Tanaka, T., “Characterization of marine microalga, *Scenedesmus sp.* strain JPCC GA0024 toward biofuel production”, *Biotechnol Lett.* 31:1367-1372, 2009.
- [8] Quevedo, C.O., Morales, S.V., Acosta, A.C., “Crecimiento de *Scenedesmus sp.* en diferentes medios de cultivo para la producción de proteína microalgal”, *VITAE. Revista de la Facultad de Química Farmacéutica UdeA.* 15(1):23-29, 2008.
- [9] Lara, M.J., “Producción de microalgas *Scenedesmus spinosus* en un fotobioreactor tubular”, Memoria de Título. Ing. Agroind. Universidad de Concepción. Fac. Ing. Agr. Chillán. Chile, 2011.



- [10] Grobbelaar, J.U., “Algal nutrition. In: A. Richmond, Editor, Handbook of microalgal culture: biotechnology and applied phycology”, Blackwell (2004), pp. 97–115, 2004.
- [11] Camacho Rubio, F.G., Fernández, A., García Camacho, F., Sánchez Pérez, J.A., Molina Grima, E., “Prediction of dissolved oxygen and carbon dioxide concentration profiles in tubular photobioreactors for microalgal culture”, *Biotechnol Bioeng* 62: 71–86, 1999.
- [12] Carvalho, A.P., Meireles, L.A., Malcata, F.X., “Microalgal reactors: a review of enclosed system designs and performances”, *Biotechnol Prog* 22: 1490–1506, 2006.
- [13] Contreras-Flores, C., Peña-Castro, J.M., Flores-Cotera, L.B., Cañizares-Villanueva, R.O., “Avances en el diseño conceptual de fotobiorreactores para el cultivo de microalgas”, *INCI*, ago. 2003, vol.28, no.8, p.450-456. ISSN 0378-1844, 2003.
- [14] Molina Grima, E., Fernández, J., Ación Fernández, F.G., Chisti, Y., “Tubular photobioreactor design for algal cultures”, *Biotechnol* 92: 113–131, 2001.
- [15] Kumar, A., Ergas, S., Yuan, X., Sahu, A., Zhang, Q., Dewulf, J., Malcata, X., Langenhove, H.V., “Enhanced CO<sub>2</sub> fixation and biofuel production via microalgae: recent developments and future directions”, *Trends in Biotechnology* 28: 371-380, 2010.
- [16] Olaizola, M., Bridges, T., Flores, S., Griswold, L., Morency, J., Nakamura, T., “Microalgal removal of CO<sub>2</sub> from flue gases: CO<sub>2</sub> capture from a coal combustor”, U.S. Department of Energy under award No. DE-FC26-00NT40934, 2006.
- [17] Yoo, C., Jun, S.Y., Lee, J.Y., Ahn, C.Y., Oh, H.M., “Selection of microalgae for lipid production under high levels carbon dioxide”, *Bioresour. Technol.* 101(1): S71-S74, 2010.
- [18] Hernández-Reyes, E., Martínez-Roldán, A., Cañizares-Villanueva, R., “Contenido de lípidos en dos especies del género *Scenedesmus* para la eventual producción de bioenergéticos”, En: XIII Congreso Nacional de Biotecnología y Bioingeniería y VII Simposio Internacional de Producción de Alcoholes y Levaduras: 21 a 26 de junio, 2009 Acapulco, Guerrero, Hotel Fairmont Acapulco Princess, 2009.
- [19] Ho, S.H., Chen, W.M., Chang, J.S., “*Scenedesmus obliquus* CNW-N as a potencial candidate for CO<sub>2</sub> mitigation and biodiesel production”, *Bioresour. Technol.* 101: 8725-8730, 2010.
- [20] Moraes, L., Martins da Rosa, G., Barcelos Cardias, B., Oliveira dos Santos, L., Vieira Costa, J.A., “Microalgal biotechnology for greenhouse gas control: Carbon dioxide fixation by *Spirulina* sp. at different diffusers”, *Ecological Engineering* 91: 426-431, 2016.
- [21] Hernández, A.P., “Desarrollo y habilitación de un controlador y registrador, para un reactor de microalgas”, *Habilitación Profesional. Ing. Civil Agric. Universidad de Concepción. Fac. Ing. Agr. Chillán. Chile*, 2010.
- [22] Guschina, I.A., Harwood, J.L., “Lipids and lipid metabolism in eukaryotic algae”, *Prog Lipid Res* 45: 160–186, 2006.